

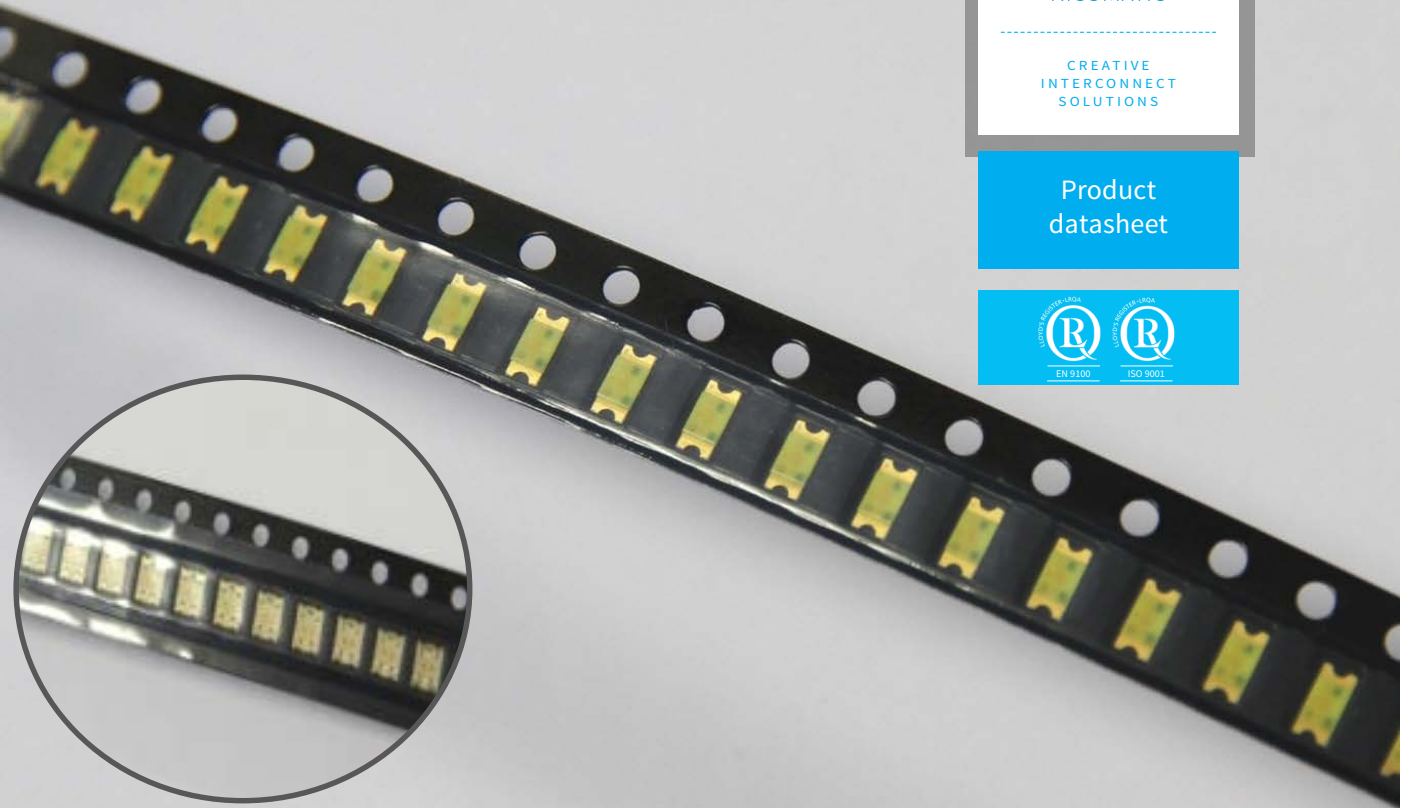

NICOMATIC

CREATIVE  
INTERCONNECT  
SOLUTIONS

Product  
datasheet



# LED

ULTRA-THIN  
0.5 mm HIGH

## ADVANTAGES

- 0.5mm high
- Easy to place size versus other packaging
- Reduce spacer thickness and/or eliminate embossing (cost reduction!)
- Market standard tape & reel for automated pick & place machines
- Can be run at lower current levels

## FUNCTIONALITIES

- Specific DESIGN for Printed Conductive Ink

# TECHNICAL DATA

## ELECTRO-OPTICAL CHARACTERISTICS ( $I_F=20\text{mA}$ / $T_a=25^\circ\text{C}$ )

Part Number	Lens Type	Emitting Color	Die Material	Dominant Wavelength $\lambda_d$ (nm)	Luminous Intensity $I_v$ (mcd)		Forward Voltage $V_F$ (V)		Reverse Current $I_R$ max ( $\mu\text{A}$ ) @ $V_R = 5\text{V}$
					Min.	Typ.	Typ.	Max.	
ZUR55W-05	Water Clear	Red	AlGaInP	624	32	74	2	2.4	10
ZUO55W-05	Water Clear	Orange	AlGaInP	605	32	45	2	2.4	10
ZUY55W-05	Water Clear	Yellow	AlGaInP	589	32	45	2	2.4	10
ZMG55W-05	Water Clear	Green	AlGaInP	573	16	35	2	2.4	10
ZUB55W-05	Water Clear	Blue	InGaN	470	36	48	3.5	4.3	50
ZPW55D-05	Yellow Diffused	White	InGaN	-	45	76	2.7	3.15	10
BURMG57W-05	Water Clear	Red Green	AlGaInP	624 573	45 16	74 35	2 2	2.4 2.4	10
BUYMG57W-05	Water Clear	Yellow Green	AlGaInP	589 573	32 16	45 35	2 2	2.4 2.4	10
BURUY57W-05	Water Clear	Red Yellow	AlGaInP	624 598	45 32	74 45	2 2	2.4 2.4	10
ZHR55W-05	Water Clear	High Red	AlGaInP	639	40	94	2	2.4	10
ZHG55W-05	Water Clear	High Green	InGaN	518	125	160	3.3	3.7	50
ZHB55W-05	Water Clear	High Blue	InGaN/SiC	465	46	78	2.7	3.2	50

Viewing angle = 140 deg for all.

## PACKAGE DIMENSION & RECOMMENDED SOLDER PATTERN

Mono-color type

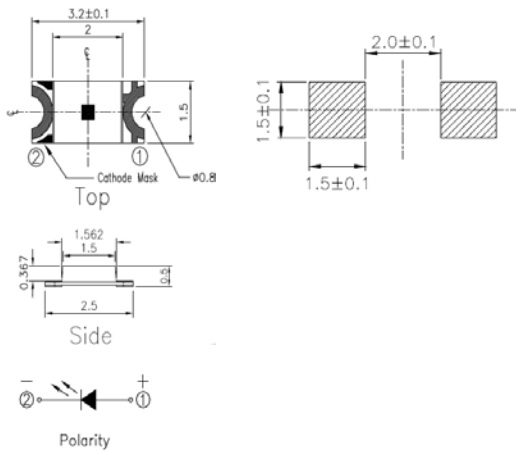

Bi-color type

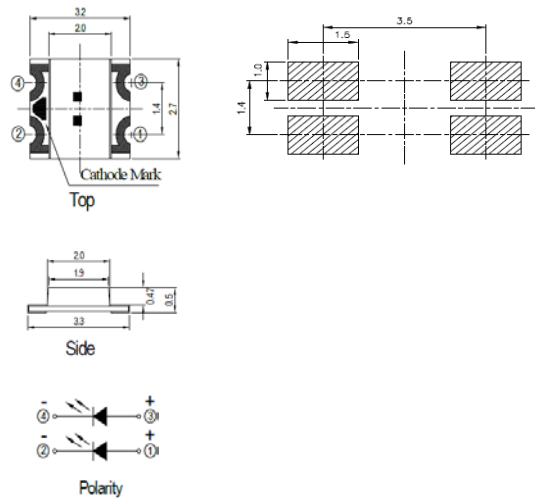

## CARRIER TAPE DIMENSION

Mono-color tape

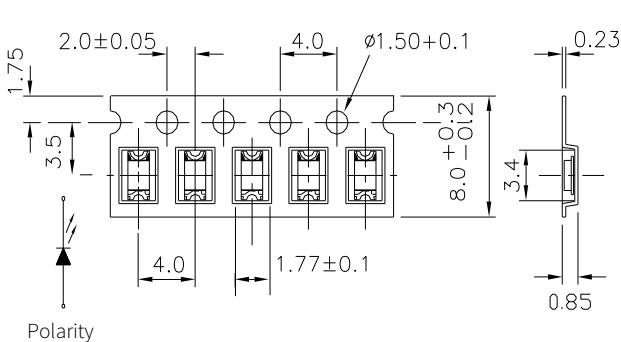

Bi-color tape

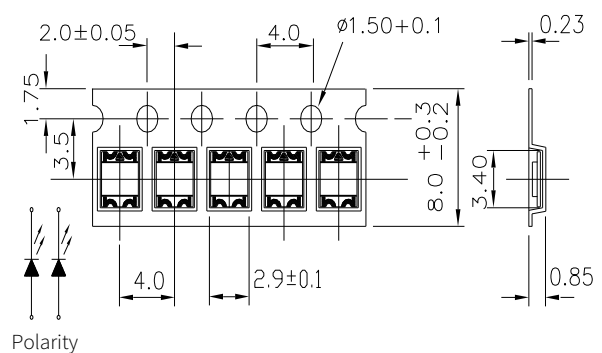

# TECHNICAL DATA

## PRODUCT CHARACTERISTICS (ABSOLUTE MAXIMUM RATINGS)

	Red / Orange / Yellow / Green High Red	Blue	White High Green	High Blue
Reverse voltage $V_R$	5V			
Forward current $I_F$	25 mA	10 mA	25 mA	15 mA
Peak Forward Current $I_{FP}$ (Duty 1/10 @ 1KHz)	60mA	100 mA	100 mA	35 mA
Power Dissipation $P_d$	60 mW	40 mW	110 mW	65 mW
Electrostatic Discharge (ESD)	2000 V	150 V	150 V	1000 V
Operating temperature $T_{opr}$	-40°C to +85°C			
Storage temperature $T_{stg}$	-40°C to +90°C			
Soldering temperature $T_{sol}$	260°C for 10 sec. 350°C for 3sec.			

**WARNING**

Tolerances:

- Luminous Intensity ( $I_v$ ):  $\pm 11\%$
- Dominant Wavelength ( $\lambda_d$ ):  $\pm 1nm$
- Forward Voltage ( $V_f$ ):  $\pm 0.1V$

## TYPICAL ELECTRO-OPTICAL CHARACTERISTICS CURVES

Red / Orange / Yellow / Green  
High Red

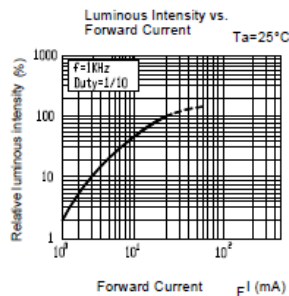
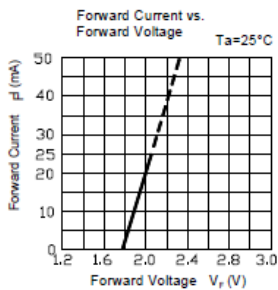

White  
High Green / High Blue

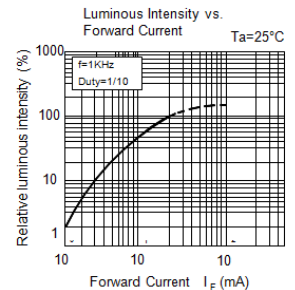
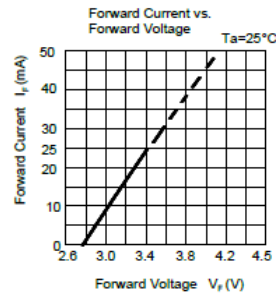

Blue

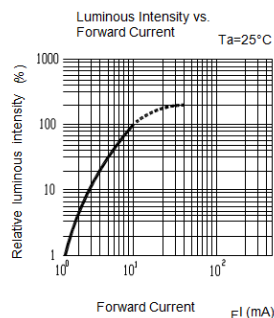
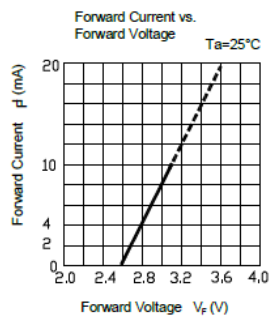

## OTHER INFORMATION

### PRECAUTIONS FOR USE

#### Electrostatic Discharge (ESD) protection

**WARNING**



The symbol to the left denotes that ESD precaution is needed. ESD protection for GaP and AlGaAs based chips is necessary even though they are relatively safe in the presence of low static-electric discharge. Parts built with AlInGaP, GaN, or/and InGaN based chips are **STATIC SENSITIVE devices**. **ESD precaution must be taken during design and assembly**. If manual work or processing is needed, please ensure the device is adequately protected from ESD during the process.